

## MODEL 4602 ACCELEROMETER

### SPECIFICATIONS

- MEMS DC Accelerometer
- Ultra-Stable, DC Response
- Exceptional Thermal Performance
- <2.0% Total Error Band
- <0.1% Linearity Accuracy

The Model 4602 is an ultra-stable MEMS DC accelerometer with exceptional performance over a full operating temperature range of -55°C to +125°C. The accelerometers are available in ranges from  $\pm 2$  to  $\pm 200g$  with a wide bandwidth from DC to 2700Hz. The model 4602 accelerometers incorporate gas damped variable capacitance MEMS sensing element with integral over-range stops for high-g shock protection. The accelerometers are designed for 4 to 30Vdc excitation voltage and include a self-test option.

For a triaxial version, TE Connectivity also offers the model 4630 accelerometer.

### FEATURES

- $\pm 2g$  to  $\pm 200g$  Dynamic Range
- Self-test Enabled
- Amplified Output, Signal Conditioned
- Gas Damped MEMS Sensors
- Integral Strain Relief
- 4 to 30Vdc Excitation Voltage
- 6000g Shock Protection

### APPLICATIONS

- Flight Testing
- Flutter and Nacelle Vibrations
- Structural Testing
- Test and Instrumentation
- Performance Testing
- Transportation



**PERFORMANCE SPECIFICATIONS**

All values are typical at +24°C, 80Hz and 12Vdc excitation unless otherwise stated. TE Connectivity reserves the right to update and change these specifications without notice.

Parameters								Notes
<b>DYNAMIC</b>								
Range (g)	±2	±5	±10	±30	±50	±100	±200	
Sensitivity (mV/g)	1000	400	200	67	40	20	10	
Frequency Response (Hz)	0-700	0-1100	0-2000	0-2300	0-2700	0-2700	0-2700	±5%
Non-Linearity (%FSO)	±0.1	±0.1	±0.1	±0.1	±0.1	±0.1	±0.1	
Transverse Sensitivity (%)	<2	<2	<2	<2	<2	<2	<2	<1 Typical
Damping Ratio	0.7	0.7	0.7	0.7	0.7	0.7	0.7	
Shock Limit (g)	6000	6000	6000	6000	6000	6000	6000	
Residual Noise (µV RMS)	360	380	400	440	480	500	500	Passband
Spectral Noise (µg/√Hz)	14	28	45	137	231	464	920	Passband

<b>ELECTRICAL</b>								
Zero Acceleration Output (mV)	±50							Differential
Excitation Voltage (Vdc)	4 to 30							
Excitation Current (mA)	<5							
Common Mode Voltage (Vdc)	1.65							
Full Scale Output (differential)	±2 Vpk (FSO=2V)							
Full Scale Output (single-ended)	+0.65 to 2.65 Vpk (FSO=1V)							
Output Resistance (Ω)	<100							
Insulation Resistance (MΩ)	>100							@100Vdc
Turn On Time (msec)	<100							
Ground Isolation	Isolated from Mounting Surface							

<b>ENVIRONMENTAL</b>								
Thermal Zero Shift (%FSO/°C)	±0.004							Typical
Thermal Sensitivity Shift (%/°C)	±0.008							Typical
Operating Temperature (°C)	-55 to 125							
Storage Temperature (°C)	-55 to 125							
Humidity	Epoxy Sealed, IP65 (MEMS sensor and high impedance electronics hermetically sealed)							
Total Error Band	<2% (RSS of Non-Linearity, Thermal Zero Shift, and Thermal Sensitivity Shift)							

<b>PHYSICAL</b>								
Case Material	Anodized Aluminum							
Cable	5x #30 AWG Conductors PFA Insulated, Braided Shield, TPE Jacket							
Weight (grams)	8							
Mounting	2x #4 or M3 Screws							
Mounting Torque	6 lb-in (0.7 N-m)							

**Calibration supplied:** CS-FREQ-0100 NIST Traceable Amplitude Calibration from 20Hz to ±5% Frequency Response Limit

**Supplied accessories:** AC-A02285 2x #4-40 (7/16 inch length) Socket Head Cap Screw and Washer

**Optional accessories:** AC-D02669 Triaxial Mounting Block  
 AC-D02744 Adhesive Mounting Adaptor  
 121 Three Channel DC Differential Amplifier

The information in this sheet has been carefully reviewed and is believed to be accurate; however, no responsibility is assumed for inaccuracies. Furthermore, this information does not convey to the purchaser of such devices any license under the patent rights to the manufacturer. TE Connectivity reserves the right to make changes without further notice to any product herein. TE Connectivity makes no warranty, representation or guarantee regarding the suitability of its product for any particular purpose, nor does TE Connectivity assume any liability arising out of the application or use of any product or circuit and specifically disclaims any and all liability, including without limitation consequential or incidental damages. Typical parameters can and do vary in different applications. All operating parameters must be validated for each customer application by customer's technical experts. TE Connectivity does not convey any license under its patent rights nor the rights of others.

# MODEL 4602 ACCELEROMETER

## DIMENSIONS

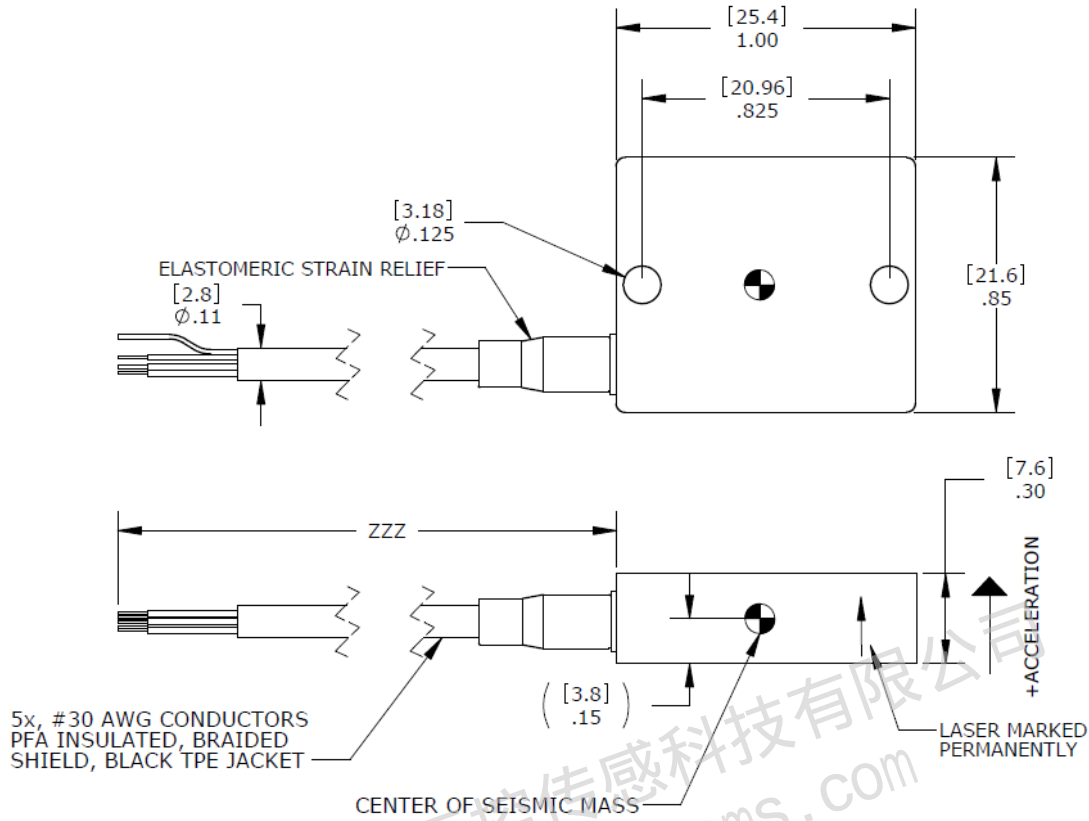

## SCHEMATIC

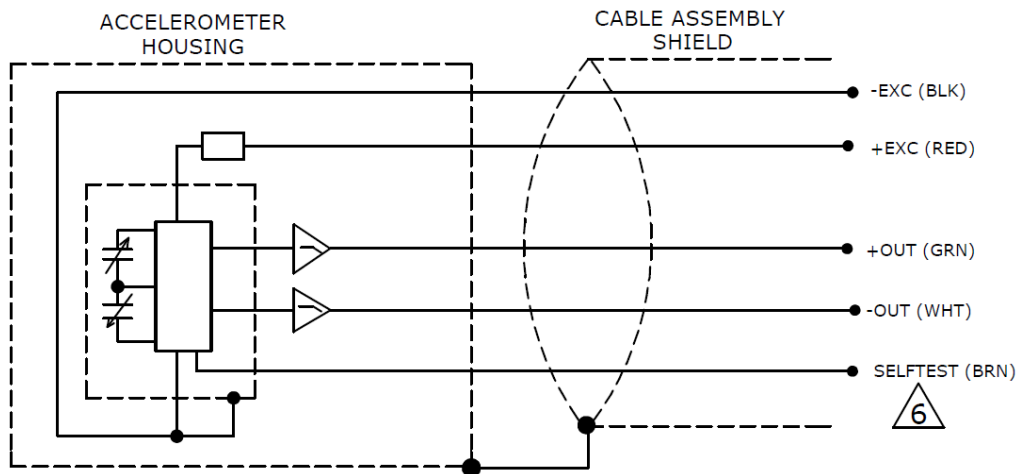

⚠ BIT: CONNECT TO CIRCUIT GROUND TO PERFORM SELFTEST WHICH PRODUCES A 24Hz, 1g PEAK-TO-PEAK AMPLITUDE, SQUARE WAVE OUTPUT SIGNAL BY MECHANICALLY ACTUATING SENSOR ELEMENT. THE SELF-TEST OUTPUT SIGNAL IS IN ADDITION TO ANY INERTIAL ACCELERATION ACTING ON THE DEVICE DURING SELF-TEST. A ZERO-G ORIENTATION PROVIDES A  $\pm 0.5g$  SELF-TEST OUTPUT SWING AROUND ZERO-G BIAS. AN AC VOLTMETER DISPLAYS A 0.5g-rms EQUIVALENT OUTPUT SHIFT. A SINGLE-ENDED HOOKUP REDUCES THE SELF-TEST OUTPUT BY HALF.

**ORDERING INFORMATION**

4602	GGG	ZZZ	D
<b>Range</b> 002=2g 005=5g 010=10g 030=30g 050=50g 100=100g 200=200g			
<b>Cable length</b> 060=60 inches 120=120 inches 180=180 inches 240=240 inches 300=300 inches 360=360 inches 480=480 inches 600=600 inches  197=197 inches, 5 meters 394-394 inches, 10 meters			

Example; 4602-010-120-D  
Model 4602, 10g range, 120inch cable length

广州工控传感科技有限公司  
www.gkmems.com

广州工控传感科技有限公司

电话：400-822-6658

邮箱：gzgk@foxmail.com

网址：www.gkmems.com

地址：广州市天河区珠江西路15号16层