

MODEL 805M1 ACCELEROMETER

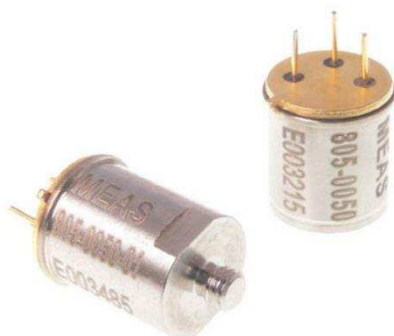

SPECIFICATIONS

- TO-5 Series Accelerometer
- 3-Wire Voltage Output
- Low-Cost, Embedded Applications
- <0.80mA Power Consumption

The Model 805M1 is a miniature adhesive mount voltage output accelerometer built on a 3-pin TO-5 header. It is available in $\pm 20g$ to $\pm 500g$ dynamic ranges and offers a flat frequency response to 12kHz. The accelerometer features a hermetic construction in a TO-5 header configuration. The model 805M1 incorporates a stable piezo-ceramic crystal with low power electronics in a 100% shielded housing suitable for many embedded OEM applications.

The model 805M1 accelerometer is offered in two configurations; one for adhesive mounting and one for stud mounting. An isolating cover option is also included for the standard model.

FEATURES

- $\pm 20g$ to $\pm 500g$ Range
- Wide bandwidth up to 12kHz
- TO-5 Configuration
- Hermetically Sealed
- -40°C to $+100^{\circ}\text{C}$ Operating Range
- Case Grounded Design
- 3.0-5.5 Excitation Voltage

APPLICATIONS

- Machine Monitoring
- Embedded Preventive Maintenance
- Low-Cost OEM Installation
- Permanent Structural Study
- Embedded Sensing Solution

PERFORMANCE SPECIFICATIONS

All values are typical at +24°C, 80Hz and 5Vdc excitation unless otherwise stated. TE Connectivity reserves the right to update and change these specifications without notice.

Parameters

DYNAMIC

	±20	±50	±100	±200	±500	Notes
Range (g)						
Sensitivity (mV/g)	100	40	20	10	4	±10%
Frequency Response (Hz)	1-8000	1-8000	1-8000	1-8000	1-8000	±1dB
Frequency Response (Hz)	0.4-10000	0.4-10000	0.4-12000	0.4-12000	0.4-12000	±3dB
Natural Frequency (Hz)	34000	34000	34000	34000	34000	
Non-Linearity (%FSO)	±1	±1	±1	±1	±1	
Transverse Sensitivity (%)	5	5	5	5	5	
Shock Limit (g)	5000	5000	5000	5000	5000	
Residual Noise (g RMS)	0.001	0.001	0.003	0.003	0.005	Broadband 1Hz to 10kHz

ELECTRICAL

Bias Voltage (Vdc)	Exc Voltage / 2					
Total Supply Current (mA)	<0.80					
Excitation Voltage (Vdc) ¹	3.0 to 5.5					
Output Impedance (Ω)	<100					
Insulation Resistance (MΩ)	>100					@50Vdc
Full Scale Output Voltage (V)	±2					
Grounding	Case grounded to mounting surface					

ENVIRONMENTAL

Temperature Response (%)	±10
Operating Temperature (°C)	-40 to +100
Storage Temperature (°C)	-54 to +125

PHYSICAL

Sensing Element	Piezo-Ceramic
Case Material	Stainless Steel
Weight (grams)	5.0
Mounting	Adhesive or Circuit Board (M3 Stud Mounting for -01 Option)

¹ The model 805M1 can be operated with 2.8V excitation but the full-scale range will be limited.

Calibration supplied: CS-SENS-0100 NIST Traceable Amplitude Calibration at 80Hz

The information in this sheet has been carefully reviewed and is believed to be accurate; however, no responsibility is assumed for inaccuracies. Furthermore, this information does not convey to the purchaser of such devices any license under the patent rights to the manufacturer. TE Connectivity reserves the right to make changes without further notice to any product herein. TE Connectivity makes no warranty, representation or guarantee regarding the suitability of its product for any particular purpose, nor does TE Connectivity assume any liability arising out of the application or use of any product or circuit and specifically disclaims any and all liability, including without limitation consequential or incidental damages. Typical parameters can and do vary in different applications. All operating parameters must be validated for each customer application by customer's technical experts. TE Connectivity does not convey any license under its patent rights nor the rights of others.

MODEL 805M1 ACCELEROMETER

DIMENSIONS

Standard Model 805M1

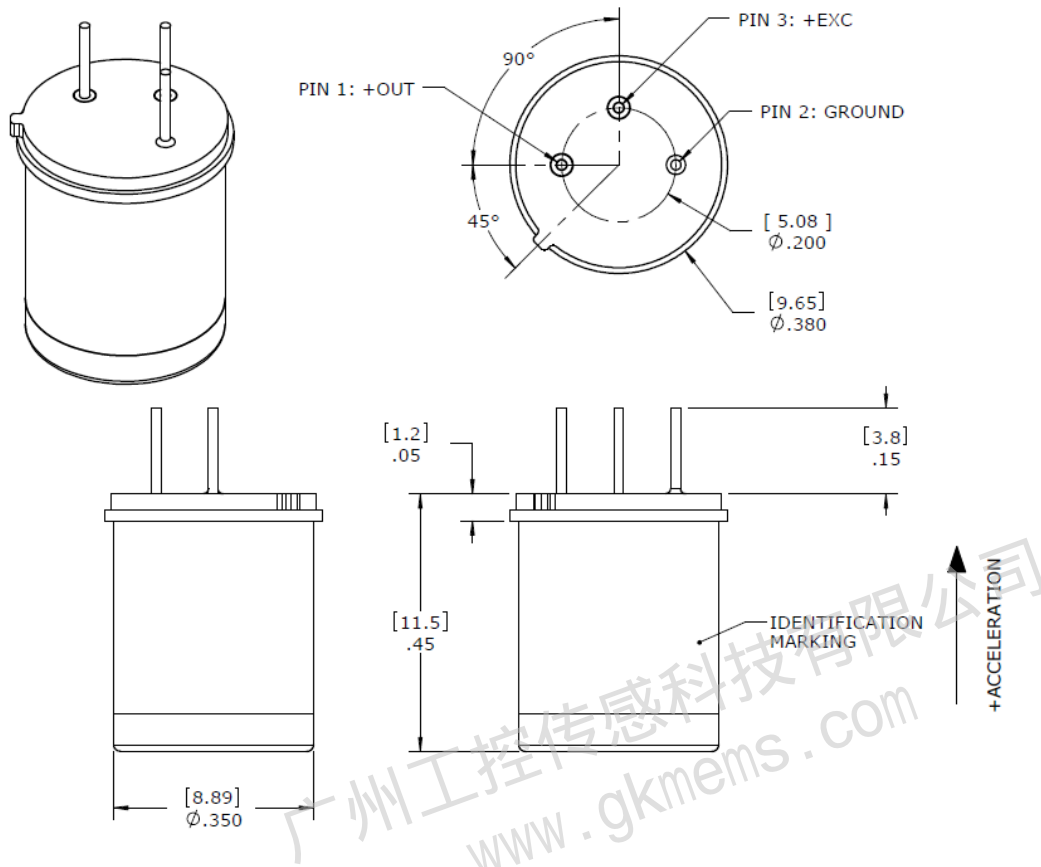

Model 805M1 with M3 Mounting Stud Option

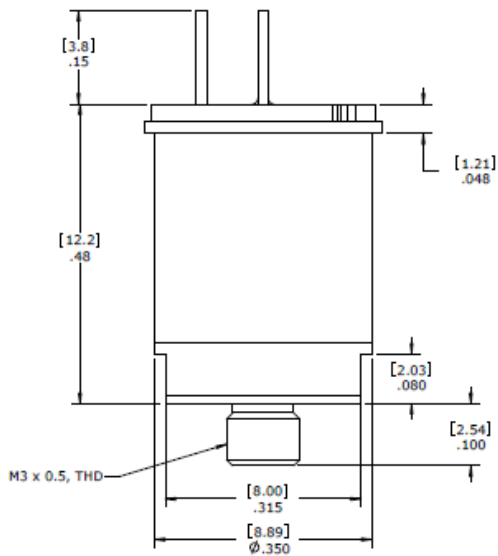

MODEL 805M1 ACCELEROMETER

SCHEMATIC

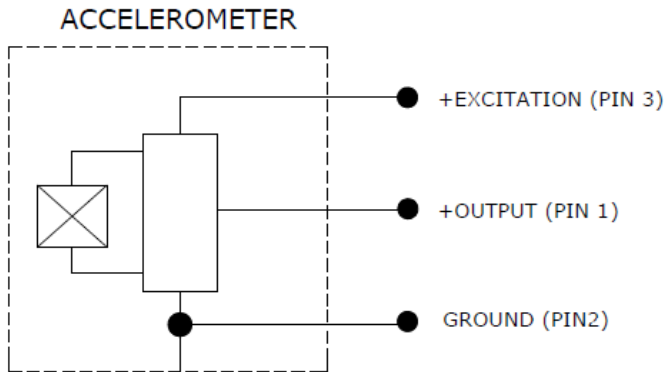

ORDERING INFORMATION

805M1

GGGG

XX

Range

0020=20g
0050=50g
0100=100g
0200=200g
0500=500g

Options

01=M3 x 0.5 Mounting Stud
02=Standard 805M1 unit with Isolating Mounting Cover Installed

Examples;
805M1-0020
Model 805M1, 20g range

805M1-0200-01
Model 805M1 with M3 mounting stud, 200g range



Isolating Cover Option

广州工控传感科技有限公司

电话: 400-822-6658

邮箱: gzgk@foxmail.com

网址: www.gkmems.com

地址: 广州市天河区珠江西路15号16层