

## LDT WITH CRIMPS VIBRATION SENSOR/SWITCH

### SPECIFICATIONS

- ◆ Piezo Film Sensors
- ◆ High Sensativity
- ◆ AC Coupled
- ◆ Laminated.
- ◆ Robust

The LDT0-028K is a flexible component comprising a 28  $\mu\text{m}$  thick piezoelectric PVDF polymer film with screen-printed silver ink electrodes, laminated to a 0.125 mm polyester substrate, and fitted with two crimped contacts. As the piezo film is displaced from the mechanical neutral axis, bending creates very high strain within the piezopolymer and high voltages are generated. When the assembly is deflected by direct contact, the device acts as a flexible "switch", and the generated output is sufficient to trigger MOSFET or CMOS stages directly. If the assembly is supported by its contacts and left to vibrate "in free space" (with the inertia of the clamped/free beam creating bending stress), the device will behave as an accelerometer or vibration sensor. Adding mass, or altering the free length of the element by clamping, can change the resonant frequency and sensitivity of the sensor to suit specific applications. Multi-axis response can be achieved by positioning the mass off center. The LDTM-028K is a vibration sensor where the sensing element comprises a cantilever beam loaded by an additional mass to offer high sensitivity at low frequencies.

### FEATURES

- ◆ Solder Tab Connection
- ◆ Both No Mass & With Mass Versions
- ◆ Withstands High Impact
- ◆ Operating Temperature: 0°C to 85°C
- ◆ Storage Temperature: -40°C to 85 °C
- ◆ Higher Temperature Version up to 125 °C available on a Custom Basis

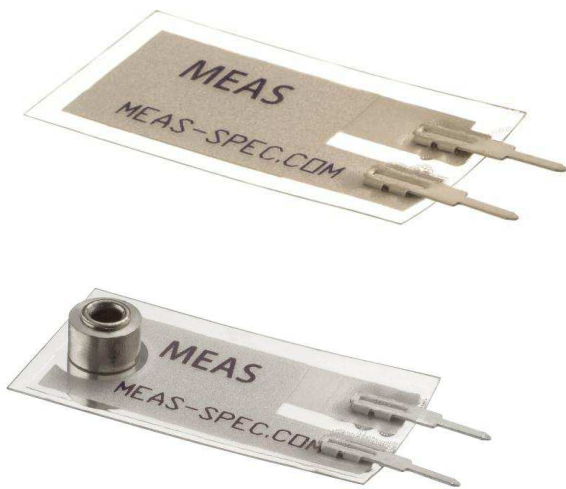

### DIMENSIONS

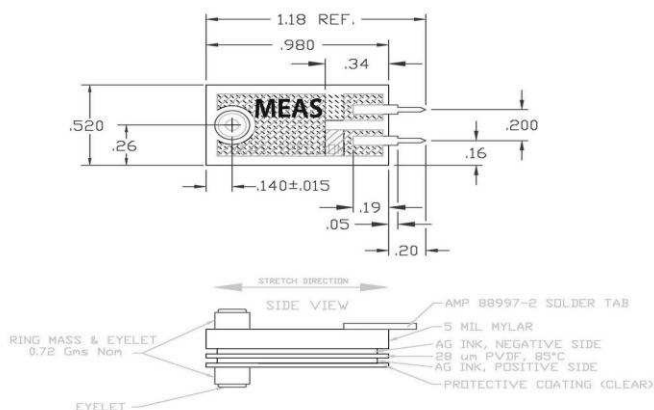
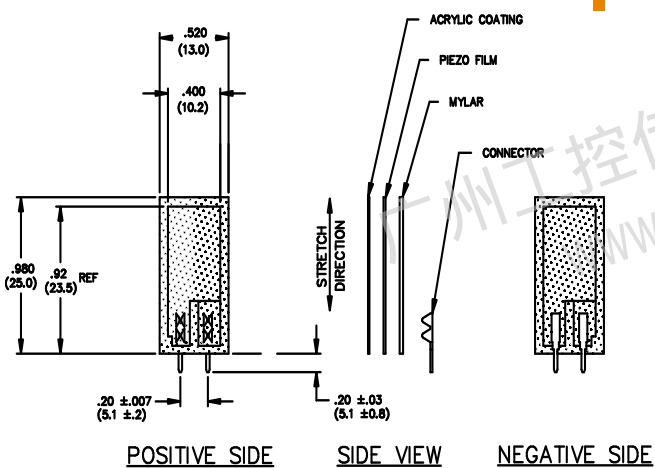

**APPLICATIONS**

- ◆ Vibration Sensing in Washing Machine
- ◆ Low Power Wakeup Switch
- ◆ Low Cost Vibration Sensing
- ◆ Car Alarms
- ◆ Body Movement
- ◆ Security Systems

**EXAMPLES OF PROPERTIES**

Four different experiments serve to illustrate the various properties of this simple but versatile component.

**Experiment #1**

**LDT0 as Vibration Sensor** - with the crimped contacts pushed through a printed-circuit board, the LDT0 was soldered carefully in place to anchor the sensor. A charge amplifier was used to detect the output signal as vibration from a shaker table was applied (using a charge amplifier allows a very long measurement time constant and thus allows the "open-circuit" voltage response to be calculated). Small masses (approximately 0.26g increments) were then added to the tip of the sensor, and the measurement repeated. Results are shown in Table 1 and the overlaid plots in Fig. 1. Without adding mass, the LDT0 shows a resonance around 180 Hz. Adding mass to the tip reduces the resonance frequency and increases "baseline" sensitivity.

**LDT0 Sensitivity: Effect of Added Mass**  
(Figure 1)

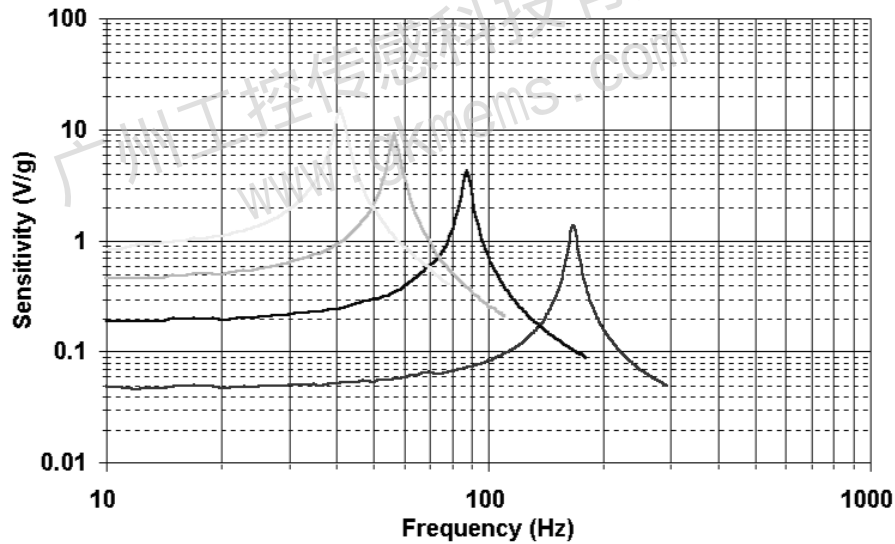
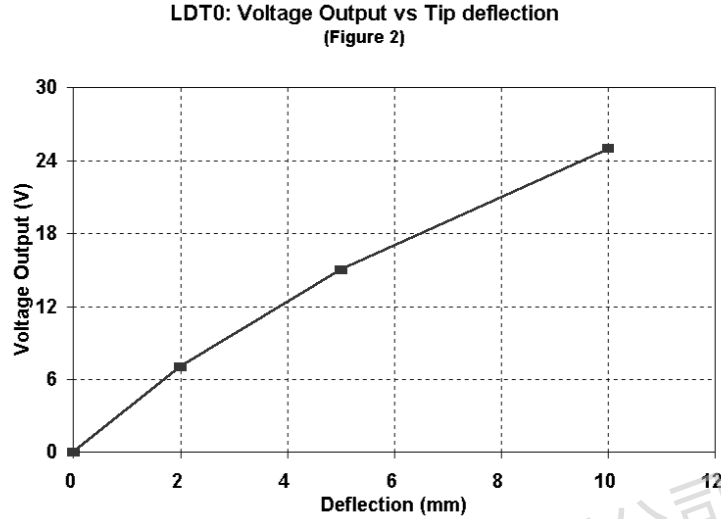

**TABLE 1: LDT0 as Vibration Sensor (see Fig 1)**

Added Mass	Baseline Sensitivity	Sensitivity at Resonance	Resonant Frequency	+3 Db Frequency
0	50 mV/g	1.4 V/g	180 Hz	90 Hz
1	200 mV/g	4 V/g	90 Hz	45 Hz
2	400 mV/g	8 V/g	60 Hz	30 Hz
3	800 mV/g	16 V/g	40 Hz	20 Hz

**Experiment #2**

**LDT0 as Flexible Switch** - using a charge amplifier to obtain "open-circuit" voltage sensitivity, the output was measured for controlled tip deflections applied to the sensor (supported by its crimped contacts as described above). 2 mm deflection was sufficient to generate about 7 V. Voltages above 70V could be generated by bending the tip of the sensor through 90° (see Table 2, Fig. 2).



**TABLE 2: LDT0 as Flexible Switch (see Fig 2)**

Tip Deflection	Charge Output	o/c Voltage Output
2 mm	3.4 nC	7 V
5 mm	7.2 nC	15 V
10 mm	10 - 12 nC	20 - 25 V
max (90°)	> 30 nC	> 70 V

**Experiment #3**

**LDT0 Electrical Frequency Response**

- when a source capacitance of around 480 pF is connected to a resistive input load, a high-pass filter characteristic results. Using an electronic noise source to generate broad-band signals, the effect of various load resistances was measured and the -3 dB point of the R-C filter determined (see Table 3, Fig. 3).

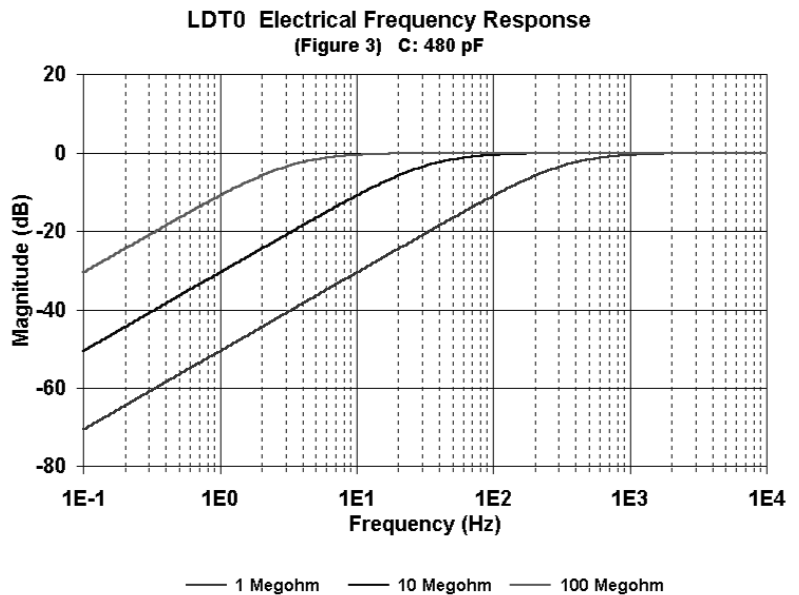

**TABLE 3: LDT0 Electrical Frequency Response (see Fig 3)  
(480 pF source capacitance)**

Load Resistance	-3 db Frequency
1 Megohm	330 Hz
10 Megohm	33 Hz
100 Megohm	3.3 Hz

**Experiment #4**

**LDT0 Clamped at Different Lengths** - using simple clamping fixture, the vibration sensitivity was measured (as in (1) above) as the clamp was moved to allow different "free" lengths to vibrate. The sensor may be "tuned" to suit specific frequency response requirements (see Table 4, Fig. 4).

**LDT0: Resonant Freq vs Clamped Length  
(Figure 4)**

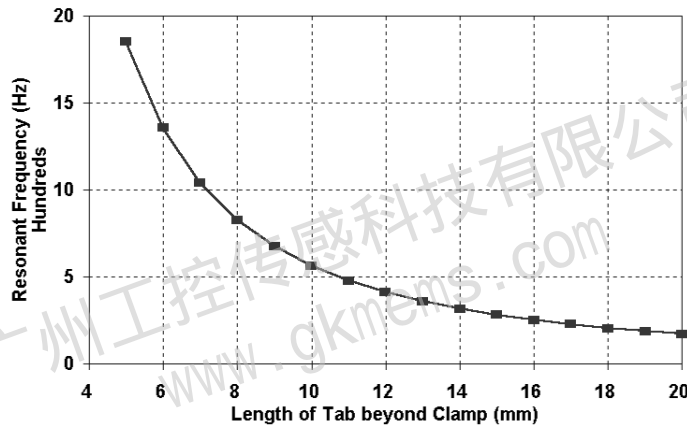

**TABLE 4: LDT0 Clamped at Different Lengths (See Fig. 4)**

Length Beyond Clamp	Resonant Frequency	Settling Time (5 cyc)
20 mm (no clamp)	180 Hz	28 msec
16 mm	250 Hz	20 msec
11 mm	500 Hz	10 msec
7 mm	1000 Hz	5 msec

**ORDERING INFORMATION**

<b>Description</b>	<b>Part Number</b>
LDT0-028K	1002794-0
LDTM-028K	1005447-1

广州工控传感科技有限公司

电话：400-822-6658

邮箱：gzgk@foxmail.com

网址：www.gkmems.com

地址：广州市天河区珠江西路15号16层

广州工控传感科技有限公司  
www.gkmems.com